

Electronic Jet Kit™ Instructions



Thank you for choosing the Techlusion Electronic Jet Kit, the TFI. The TFI is usable only for 2006 Dyna model fuel injected Harley Davidson's.

This product is a perfect fit for stock bikes with exhaust/intake and other various engine mods.

This is an Electronic Jet Kit. Like jet kits in the past, the more you modify, the more responsibility you take in getting your fuel curve right. Going to Dobeckperformance.com will help you obtain better high horsepower tuning.

TOOLS REQUIRED

- This is about a 60-minute install time.
- The tools required to disconnect the negative terminal of the battery.
- The tools required to remove your seat.
- The tools required to remove your front O2 sensor caddy located with the voltage regulator.
- The tools required to loosen and prop up the fuel tank.

Electronic Jet Kit™ Instructions



1. Before installing the TFI you must first disconnect the negative lead from the battery.
2. Determine a location for the TFI unit. Suggested locations are as follows: Under the seat (see figure #2).
3. Making sure that your motorcycle is cold, loosen and lift up the fuel tank (be sure to disconnect the fuel line using the quick disconnect feature on the fuel fitting, **DO NOT UNSCREW THE FITTING**) and remove the front and rear mounting bolts you will need something to hold the fuel tank up (block of wood or a towel) from the frame to gain access to the injectors.
4. Underneath the fuel tank you will locate the fuel injectors (see figure #5).
5. Disconnect the factory injector connectors from the fuel injectors and replace with the TFI injector connectors from the TFI unit, (see figures #6,7,8). **You must match the (TFI) harness with the white/yellow stripe wire to the front cylinder and the (TFI) harness with the green/gray stripe to the rear cylinder.** We recommend that the (TFI) harness should run along the left side of the frame backbone to the injectors along with the front O2 sensor (TFI) harness. **It is a good idea to make sure there is a little slack at the connections to prevent engine vibration from damaging/breaking a wire on the connectors.**
6. The front (factory) O2 harness is located at the voltage regulator in between the down tubes of the frame just behind the front tire (see figure #3). The front (TFI) O2 harness (long purple harness) will run along the left side of the frame down to the voltage regulator. The voltage regulator has a plastic connector caddy attached to it that houses the front O2 sensor harness connection. You will need to remove the voltage regulator to disassemble the harness caddy. Once you have gained access to the O2 harness, connect the TFI O2 harness in between the factory O2 harness connection (see figure # 9). Zip tie the extra connectors/harness to the back of the caddy and reinstall caddy and voltage regulator to the frame.
7. The rear O2 harness (short pink/tan harness) is located under the seat (see figure #4) inside the frame opening. Once you have gained access to the O2 harness, connect the TFI O2 harness in between the factory O2 harness connection and reinsert the harness into the frame opening.
8. Replace the fuel tank. (making sure that all mounting bolts are in place and fuel connections are correct).
9. Connect the TFI ground lead to the negative terminal of the battery along with the factory ground lead.

Electronic Jet Kit™ Instructions



1. After connecting the box, check all the wire connections to ensure proper connection. To do this just pull on the connections to make sure they are *properly locked in*.
2. Be sure to check that the wire harnesses are not in direct contact with any sharp edges or other objects which could result in long term wear.
3. Start the bike up and in approximately four seconds the lights inside the Gen 3 will energize and be visible. With a proper installation, the Gen 3 will have a continuous lighting sequence where the lights come on from left to right and then back again and repeats this display for about eight seconds. With an improper installation the light display will consist of a flashing green and a flashing red light. This occurs when the Gen 3 is not receiving a proper injector signal. Recheck the wire connections for any defects. *(The flashing green and flashing red lights is common for a proper installation during deceleration because the stock fuel map shuts off the fuel injectors during this process.)*
4. At this point you are ready to adjust the Gen 3 to the base settings supplied with the unit. The first thing to do is ensure that the proper code was supplied by checking that the four programmable features are available. To begin this process press the MODE button and to enter each successive mode, just press the MODE button again. *Note that every mode will be identifiable by a flashing light on the left side of the light display. This signifies the min value for this mode, which can be increased later.*
 - a. The **first mode** represents the cruise fuel adjustment. A flashing green light should appear on the left side of the light display.
 - b. The **second mode** represents an additional amount of fuel added during acceleration. A flashing yellow light should appear on the left side of the light display.
 - c. The **third mode** represents an additional amount of fuel added during full throttle. A flashing red light should appear on the left side of the light display.
 - d. The **fourth mode** is an adjusted value to determine the time when the full throttle fuel amount kicks in. A blue light appears on the right side and a flashing red light appears on the left side of the light display.

Electronic Jet Kit™ Instructions



If each mode is present then the proper code exists and you are ready for making manual adjustments. If you failed to enter a mode, try going through the sequence again and be sure to only press the MODE button once in between each step.

5. You are now ready to manually program each mode. Consult the base settings supplied with the unit or you can look up the most up-to-date settings by going to our website <http://www.dobeckperformance.com>.

To program the Gen 3, the bike must be running in order to supply power to the box.

If at anytime you stay in an adjusting mode for longer than 15 seconds without pressing any buttons, the Gen 3 will exit adjusting mode and will return to the ready state.

To save settings at a particular mode press the MODE button which goes to the next adjustable mode or wait for the Gen 3 to exit back to the ready state.

The settings are adjusted by pressing the plus and minus buttons located on the right and left side respectively of the mode button. When entering each mode for the first time, remember a light is flashing on the left side, which signifies a value of 0 for that particular mode. To start adjusting press the plus button once and notice that the light which was flashing is now flashing at a faster rate. This signifies an increase of 0.5 for the mode value. Press the plus button again and the light to the right of the last flashing light will now begin flashing. This represents a value of 1 for the mode. Now if you press the plus button again you will notice the next light to the right begins flashing. You should now have two flashing lights and the current value is 1.5 for the mode. This process continues for all the lights across the light display until you reach the right most light. When the value is 7.5 you will have the second from the right light flashing in the color of the mode and the right most light will be flashing blue. Pressing the plus button will make the value 8 which is the max value and the right most light will flash a combination of the two colors. The range of values for each mode is 0 to 8. To see a visual display of adjusting values go online to dobeckperformance.com

6. Your Gen 3 should now be properly programmed and you are now ready to tune your bike.

Always make sure your bike is at normal operating temperature when making tuning adjustments.

Electronic Jet Kit™ Instructions



Tuning for mode 1 – cruise adjustment

The cruise portion is generally handled by the O2 controller. This adjustment may vary slightly from our base settings. It can primarily help with a steady throttle surge or driveability issues caused by lean emissions.

Tuning for mode 2 – fuel addition during acceleration

Tuning for this mode depends greatly upon your individual bike and can vary widely from the base setting. After market high flow exhaust systems, high flow air filters and other engine modifications can cause you to tune completely different from the base settings. This combination could have a setting difference as great as three yellow lights. Note that this adjustment is only for hard acceleration.

Tuning for mode 3 – fuel addition during full throttle

This adjustment deals with adding fuel primarily for the upper 20-25% of the RPM range. For example, running to red line in 1st, shifting, running to red line in 2nd, shifting, and continuing this all the way through the gear range, you would have been engaging the red light all the time. Again this mode could vary widely from the base settings depending on the set up of your bike and could have a difference as great as three red lights or more.

Tuning for mode 4 – point when full throttle fuel kicks in

The base setting for this mode will rarely have to be changed. The red light should be engaged during the full throttle period. For example, running to red line in 1st, shifting, running to red line in 2nd, shifting, and continuing this all the way through the gear range, the red light should be engaged the whole time. If you do not see the red light the whole time then you need to lower this setting to make the red light turn on sooner.

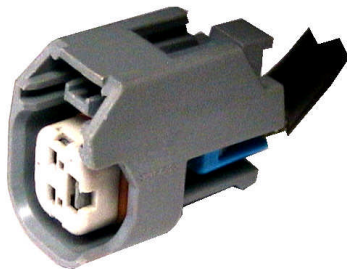

Please note that the '06 Harley Davidson Injectors have changed. Your connector will look like the image above. All other information will remain the same.

Some vehicles modifications with Techclusion Inc. products must not be used on public roads and in some cases may be restricted to close course competition. Those products not identified as US EPA legal are intended for off-road or marine applications only. Not intended for use ON emission controlled vehicles.

Electronic Jet Kit™ Instructions



Gen 3 Instructions

General Layout

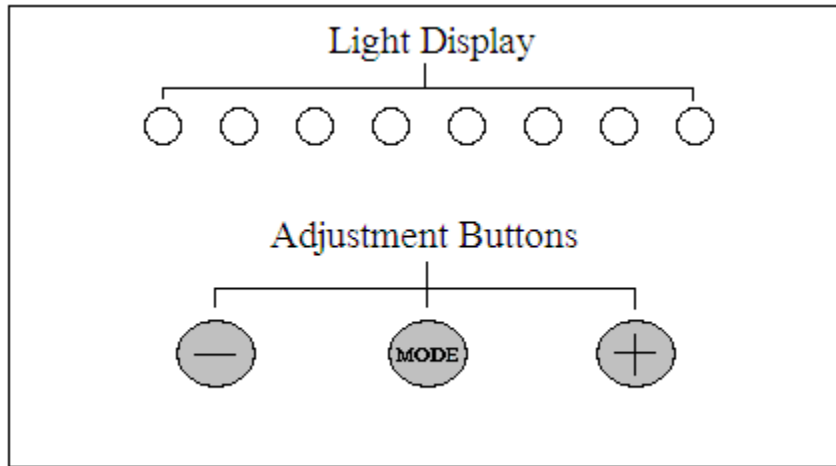

Start-Up Light Sequence

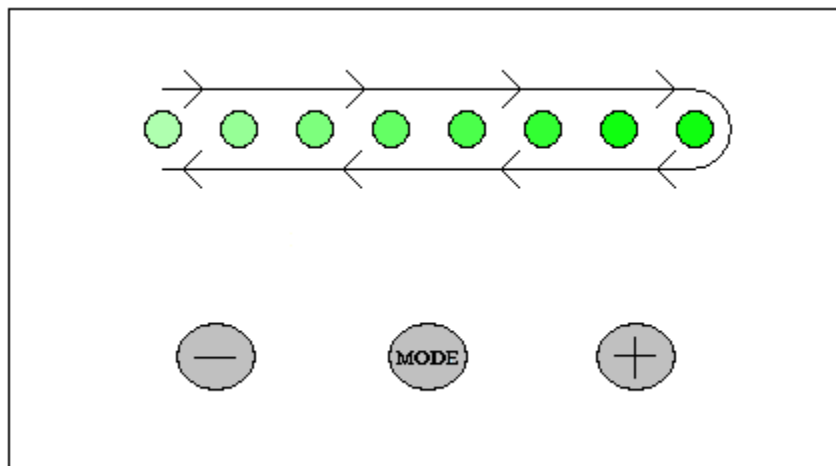

Electronic Jet Kit™ Instructions



Adjustment Modes

Mode 1 – Green

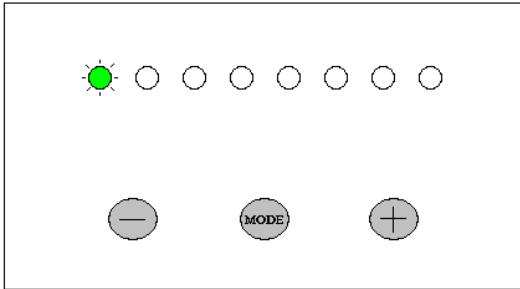

Mode 2 – Yellow

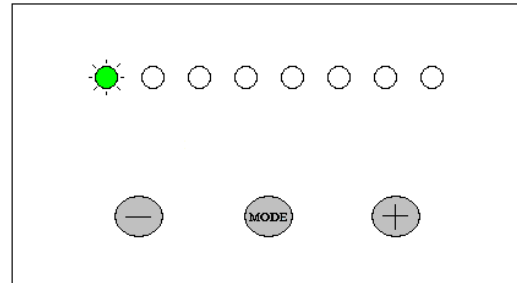

Mode 3 – Red

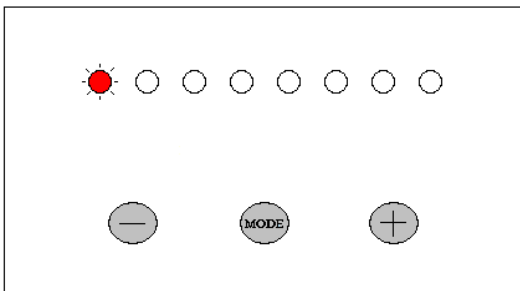

Mode 4 – Red / Blue

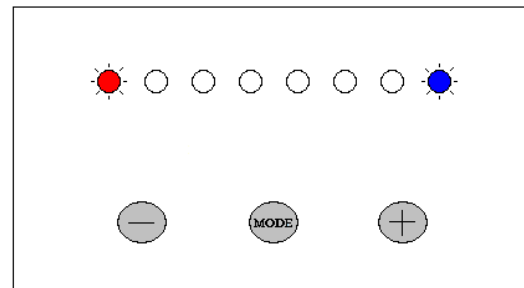

Electronic Jet Kit™ Instructions



Base Settings

Mode 1

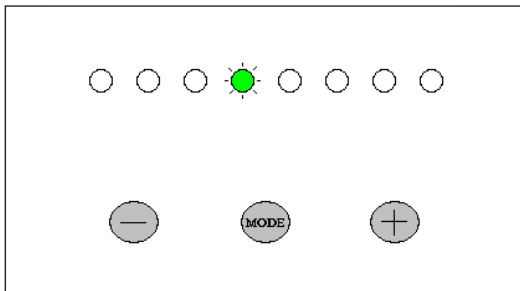

Mode 2

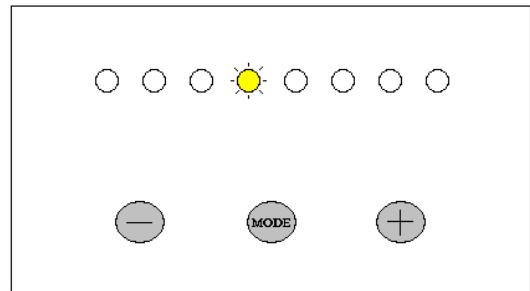

Mode 3

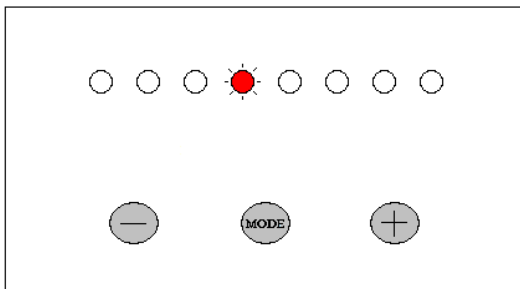

Mode 4

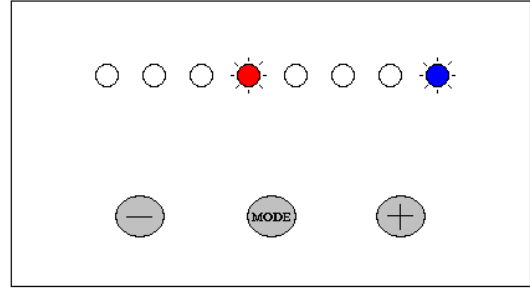

Electronic Jet Kit™ Instructions

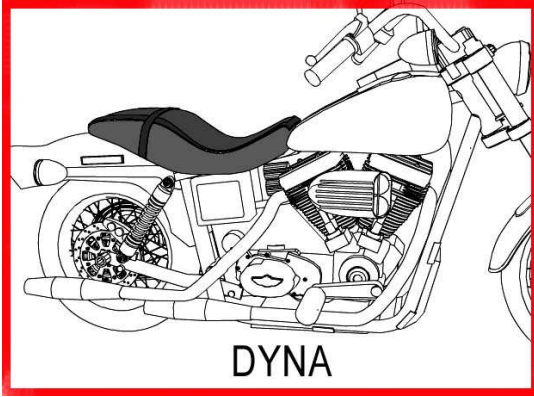

DYNA

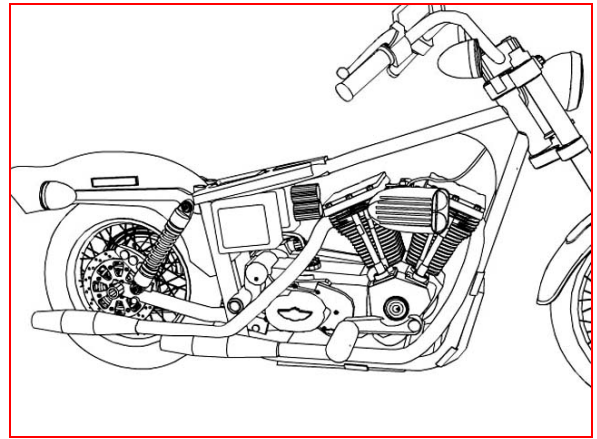

Figure 1

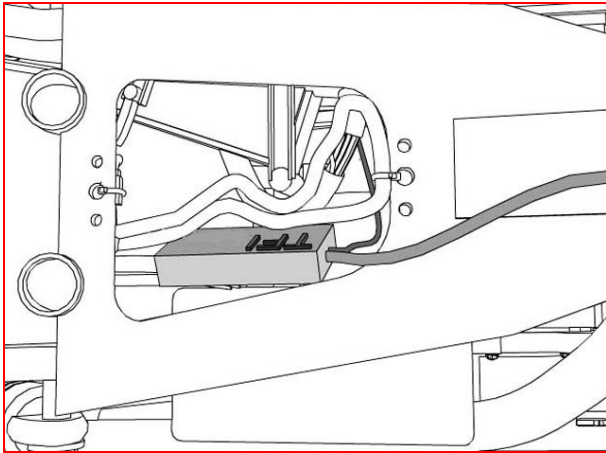

Figure 2

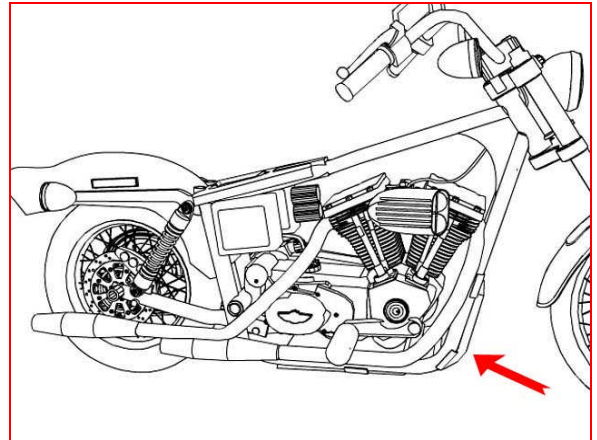

Figure 3

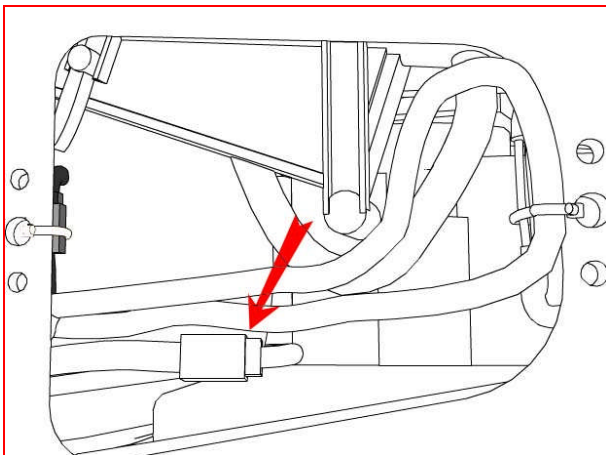

Figure 4

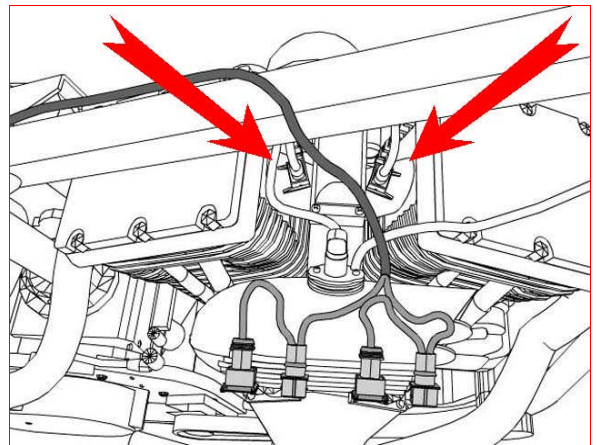

Figure 5

Electronic Jet Kit™ Instructions

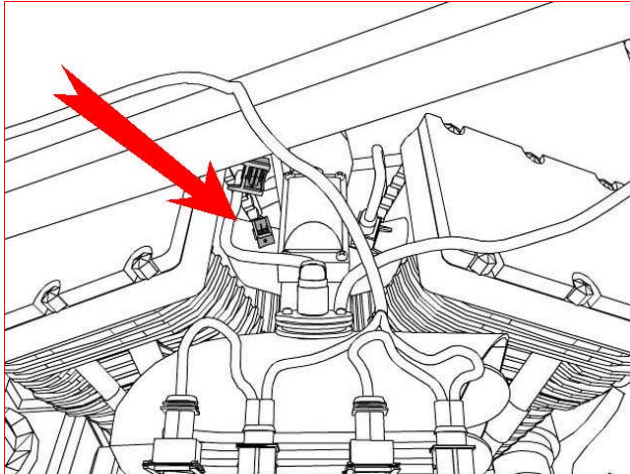

Figure 6

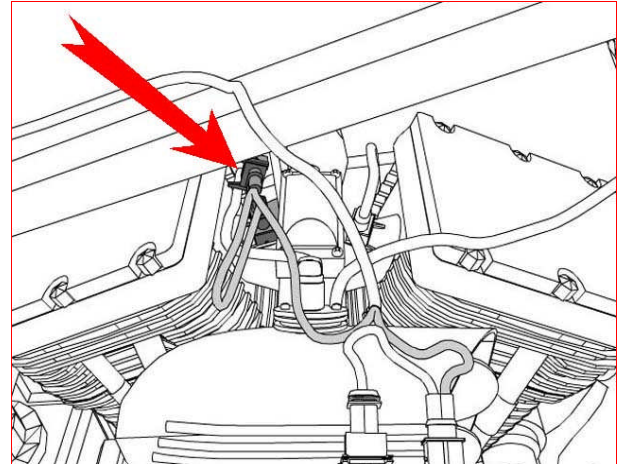

Figure 7

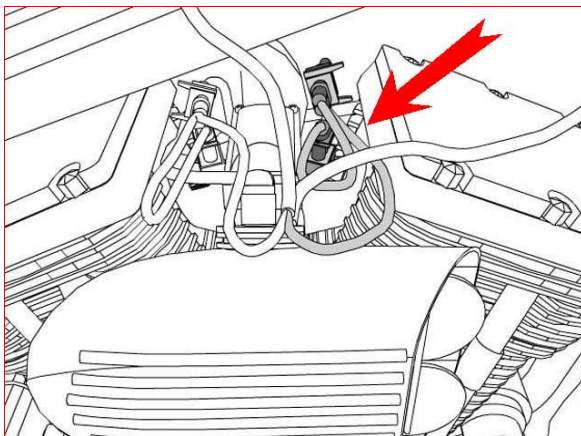

Figure 8

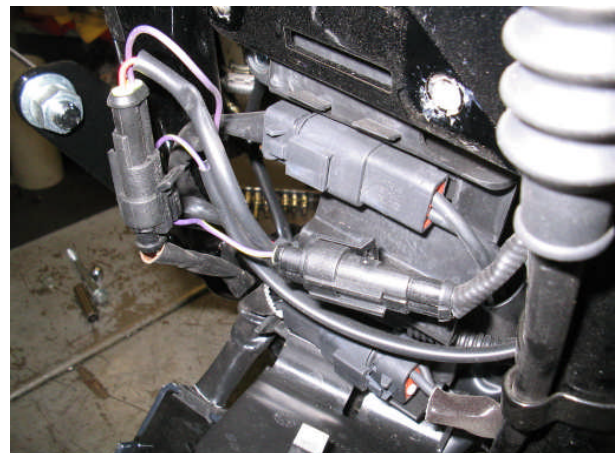

Figure 9

Electronic Jet Kit™ Instructions



2-year Unlimited Mileage Warranty

Techlusion warrants that this product carries a warranty for 2-years from date of purchase against original defects in materials and workmanship. Should this product fail to perform for either of the above reasons, Techlusion will repair or replace it with an equivalent product at no charge, except for postage, to the original retail purchaser.

*****IMPORTANT*****

To obtain the benefits of this warranty, the retail purchaser must first call 1-877-764-3337 to obtain a Return Authorization Number, then send the product with proof of purchase and postage prepaid to:

**Dobeck Performance
157 Progressive Dr.
Belgrade, MT 59714**