

Electronic Jet Kit™ Instructions



Thank you for choosing the Techlusion Electronic Jet Kit, the TFI. This TFI model is **ONLY** usable for the following Harley Davidson models:

➤ **2008-2009 TOURING Models**

This product is a great fit for stock bikes and also along with exhaust and intake mods.

This is an Electronic Jet Kit. Like jet kits in the past, the more you modify, the more responsibility you take in getting your fuel curve right. Go to www.DobeckPerformance.com will help you obtain better high horsepower tuning.

ATTN: The 1252HPST kit has double the fuel range of the standard version (1252ST). It is designed to give the tuner the ability to add far more fuel than usual for high horsepower/high compression engine setups.

Due to the complexity of the newer motorcycles, dealer install may be required.

If you have any questions during installation or tuning please call tech support.

Toll Free: 877-764-3337

USA: 406-388-2377

Business Hours: 8am-5pm MST Monday-Friday

INSTALLATION PREP

- **Install Time:** 60 minutes
- **Required Tools for:** Disconnecting the negative terminal of the battery
 Removing your seat
 Loosening and propping up the fuel tank
 Fuel adjustments (small screwdriver)



INSTALLATION

1. Before installing the TFI you must first disconnect the negative lead from the battery.
2. Determine a location for the TFI unit. We suggest under the seat or behind a side cover. (fig #1)
3. Making sure that your motorcycle is cold (be sure to disconnect the fuel line using the quick disconnect feature on the fuel fitting, **DO NOT UNSCREW THE FITTING**) and remove the rear tank mounting bolt (under the seat) loosen front bolt and lift the fuel tank up and forward (make sure not to come in contact with the steering with the front of the fuel tank when propping it up). You will need something to hold the fuel tank up (block of wood or a towel) from the frame to gain access to injectors. Removing air cleaner assembly can also help with gaining access to the injectors.
4. Underneath fuel tank locate the fuel injectors. (See owners' manual for help if needed)
5. Disconnect factory injector connectors from fuel injectors and replace with TFI injector connectors from TFI unit, **it does not matter which order they are hooked up.** (Touring fig #4,5,6,7). **It is a good idea to make sure there is a little slack in the harness to prevent engine vibration from damaging/breaking a wire on the connectors.**
6. The front factory O2 connector is located: (see owners' manual for help if needed)
TOURING - O2 connector is zip tied to the cross member/down tube area on the front portion of the frame behind the front tire. (Touring fig #3)
Disconnect factory O2 connection and plug in TFI bypass. The factory O2 sensor can be removed from the exhaust pipe used with a pipe plug and/or coil up original harness and secure.
7. The rear factory O2 connector is located: (see owners' manual for help if needed)
TOURING – fig #2 - Follow the O2 harness from the rear head pipe down to the starter.
Disconnect factory O2 connection and plug in TFI bypass. The factory O2 sensor can be removed from the exhaust pipe used with a pipe plug or coil up original harness and secure.
8. Replace the fuel tank. (Make sure all bolts are in place and fuel connections are correct).
9. Connect TFI ground lead to negative terminal of battery along with factory ground lead. (see owners' manual for help if needed)
10. With rubber plug removed from TFI, turn motorcycle key switch to the "ON" position. As the bikes electrical system goes through initial start up mode you "may" see LED's flashing on TFI for a few seconds then go out, this is normal.
11. Start motorcycle. The green LED should now be on steady and the yellow will flash rapidly for up to 15 seconds, and then go out. If green or red LEDs continue flashing after startup please refer to "TFI" section in troubleshooting guide.



Tuning – For reference, the pots are numbered from left to right on the TFI

POT #1 - GREEN LED: AIR FUEL MIXTURE SCREW ADJUSTMENT

With the TFI installed, bike fully warmed up, and screwdriver in hand, locate the GREEN LED and the first pot, which is right below it. Using the throttle, raise the RPM to a high idle or about 2000 RPM. Once there, slowly turn the green pot clockwise from the 1:00 position (off) until you achieve the highest RPM and smoothest running sound (like a mixture screw on a carburetor). You should find the best setting between 2:30 and 4:00 o'clock. If you turn the green pot clockwise and the engine does not accept any more fuel (RPM drops when adding fuel) you may have one or more of these problems (See troubleshooting Motorcycle).

POT #2 – YELLOW LED ACCELERATION FUEL ADJUSTMENT

Anytime the LED is on, this pot is adding fuel. In neutral raise the RPM slowly up through the mid range and see no yellow LED. However, opening the throttle quickly from idle you “should” see the yellow LED come on. Fine tuning: Start with the suggested setting and then add one clock position at a time until the bike says too much (hesitation) then back off 2 clock positions, if adding makes it worse go opposite direction. The yellow pot adds its fuel below 70% of maximum RPM. If no yellow LED there is not enough load to turn it on. At that point the street or dyno will be able to show the difference.

POT #3 – RED LED: MAIN FUEL ADJUSTMENT

The TFI adds about 5 points of main jet fuel with every clock position. For example, one clock position is the same as 150 to 155 main jets. Fine tuning: Start with the suggested setting and then add one clock position at a time until the bike says too much (hesitation) then back off 1 clock position, if adding makes it worse go opposite direction. The red pot adds most of its fuel above 70% of maximum RPM.

POT #4 – RPM SWITCH POINTS – SERVES TWO PURPOSES

1 - SETS RPM THE RED LED (main jet fuel) TURNS ON. One clock position is roughly 1000 RPM. This pot should be set to about 70% of redline. (For example: Harley Softail redlines at 5600 rpm and 4000 is roughly 70% of redline which would be 4:00 o'clock). Verify setting by raising the RPM in neutral, look for GREEN and YELLOW LEDs to shut off and the red to turn on at the chosen RPM. Refer to suggested settings if you have no tachometer.

2 – SHUTS OFF IDLE FUEL. In some cases modified engines can produce a richer than normal idle mixture. 1:00 o'clock through 6:00 o'clock sets RPM that the RED LED (main jet fuel) turns on. When the 4th pot is turned to 7:00 o'clock the software is instructed NOT to add fuel until 1250 RPM. Also, when setting the 4th pot at 7:00 o'clock the software automatically defaults to 4000 RPM (internally) as the RPM for the RED LED (main jet fuel) to turn on.

Some vehicles modifications with Techclusion Inc. products must not be used on public roads and in some cases may be restricted to close course competition. Those products not identified as US EPA legal are intended for off-road or marine applications only. Not intended for use ON emission controlled vehicles.



TROUBLESHOOTING

Motorcycle

Fuel injected bikes all have the same exact fuel curve and is corrected everyday by the on board weather station. Nothing is leaner than a stock fuel injection map. With our box installes and the bike fully warmed up, if you slowly turn on the green pot and the engine does not accept any more fuel (RPM drops when adding fuel) then you “may” have one or more of these problems:

1. Engine not fully warmed up.
2. A vacuum leak on the intake.
3. High lift cams affecting map at light loads and low RPM.
4. The loss of TPS and ECU sync.
5. Cylinder head temp sensor malfunction.

NOTE: The listed problems are ordered from most common to least common

TFI

If just the GREEN or RED LEDs “FLASH” after startup or no LEDs are visible or bike doesn’t start then please confirm/check connections and retry. If you still experience a problem call tech support.

If needed call tech support.

Toll Free: 877-764-3337

USA: 406-388-2377

Business Hours: 8am-5pm MST Monday-Friday

POOR MILEAGE

Solution:

1. Check your GREEN POT setting. This setting is generally responsible for 90% of your mileage. In the hundreds of installs performed, we have never gone beyond the 4:00 o’clock setting. Try backing down the green setting slightly. You can slightly lower the yellow and red settings also.
2. RPM pot adjusted too low. Make sure the RED LED is turning on no lower than 70-75% of the maximum rpm. NOTE: Some engine setups can dictate a higher or lower setting on the RPM pot.
3. Make sure your engine passes the 2000-RPM test at the beginning of the “**Tuning**” chapter.

If you still have mileage issues call tech support for further assistance.

Electronic Jet Kit™ Instructions

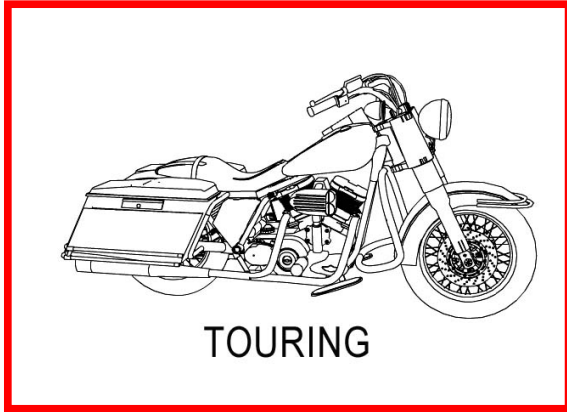

TOURING

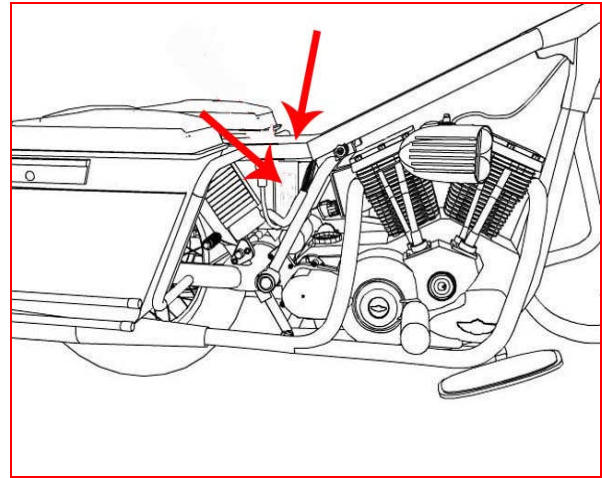

Figure 1

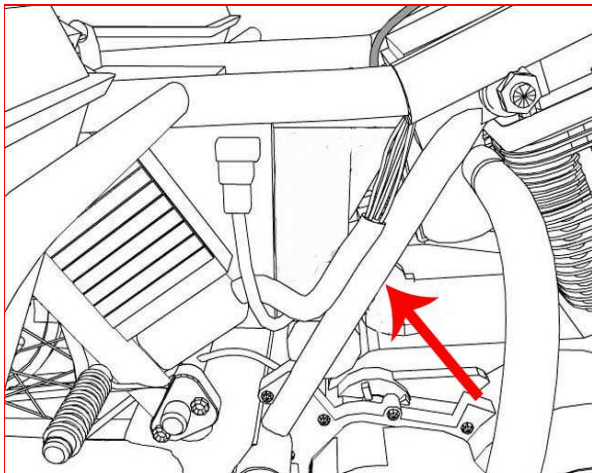

Figure 2

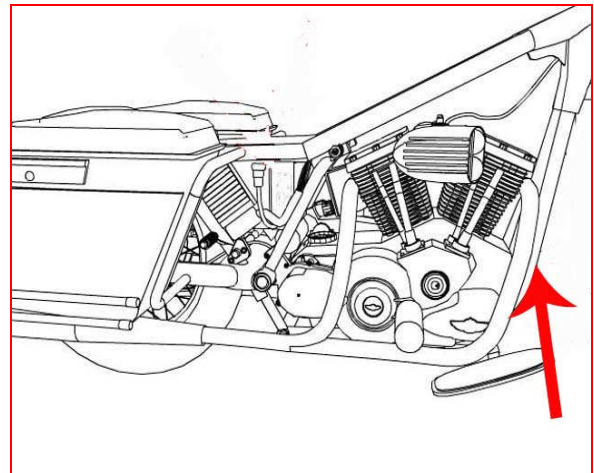

Figure 3

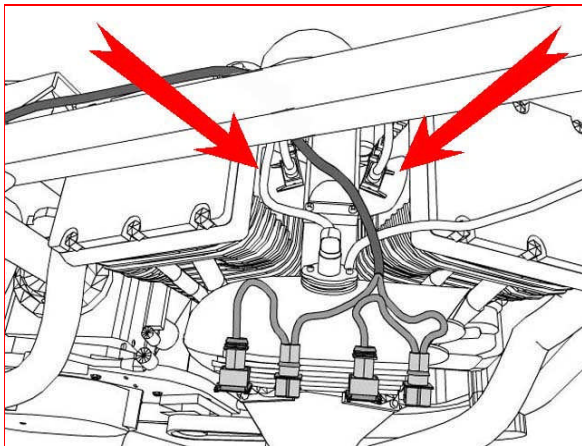

Figure 4

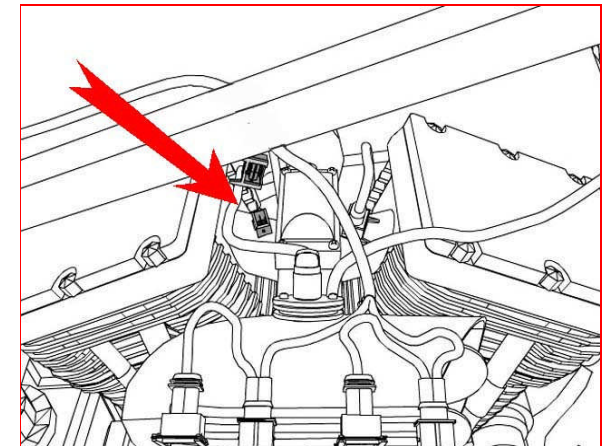

Figure 5

Electronic Jet Kit™ Instructions

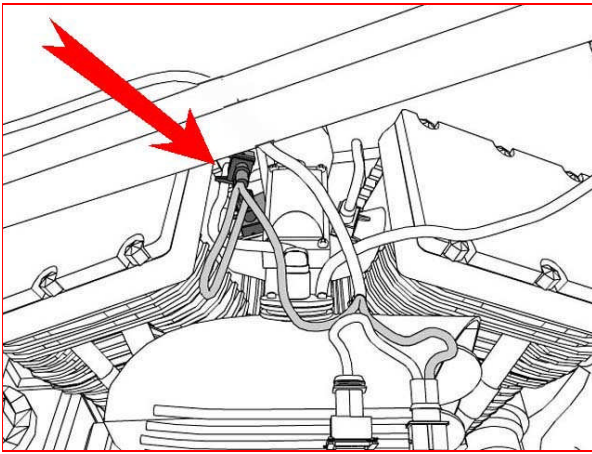

Figure 6

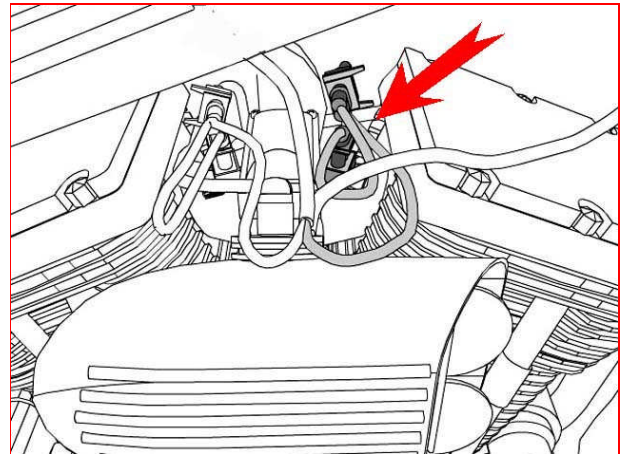

Figure 7



RECOMMENDED POT SETTINGS:

HIGH COMPRESSION / BIG BORE

GRN: 2:30

YEL: 4:00

RED: 3:30

RPM: 4:00

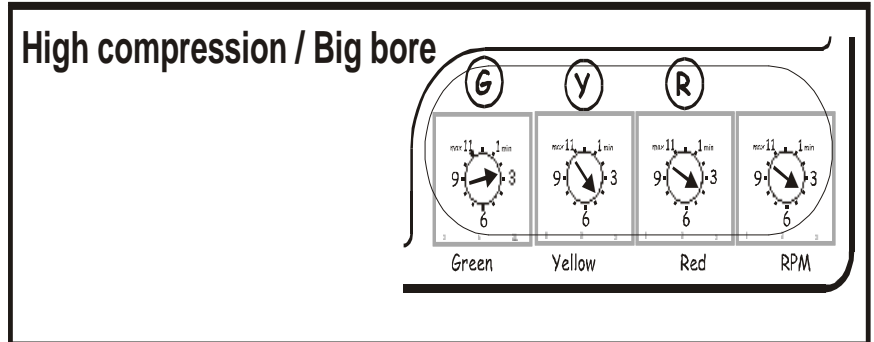

**NOTE: ALL SETTINGS ARE GIVEN AS
ACTUAL WALL CLOCK SETTINGS.
PLEASE IGNORE THE NUMBERS ON
THE POTS!!**



Techlusion Corporation dba Dobeck Performance warrants that this product carries a warranty for 2 years from date of purchase against original defects in materials and workmanship to the original purchaser. Should this product fail to perform for either of the above reasons, Techlusion will repair or replace it with an equivalent product at no charge except for postage.

To obtain the benefits of this warranty, the purchaser must first call Techlusion to obtain a Return Merchandise Authorization (RMA) number. The purchaser can then send the product with proof of purchase date to:

**Dobeck Performance
Attn: Warranty Department
157 Progressive Drive
Belgrade, MT 59714**

**Toll Free: 877-764-3337
USA: 406-388-2377
Business Hours: 8am-5pm MST Monday-Friday**